

CAD FILE:

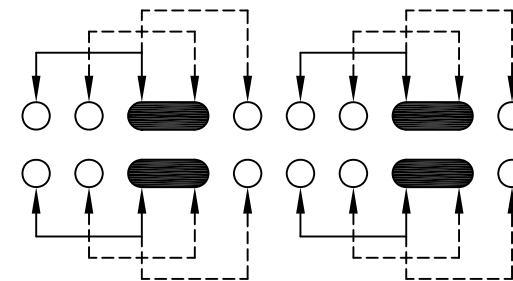

SCHEMATIC (SHORTING)

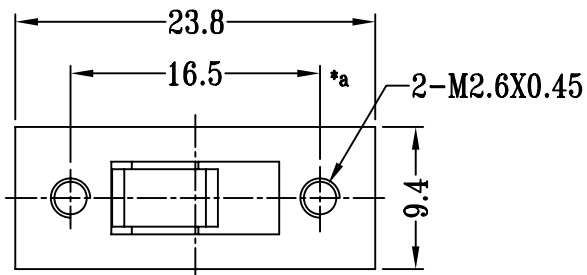
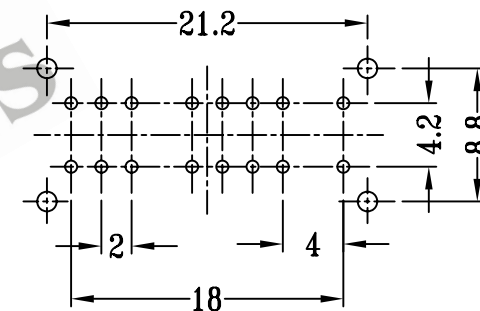
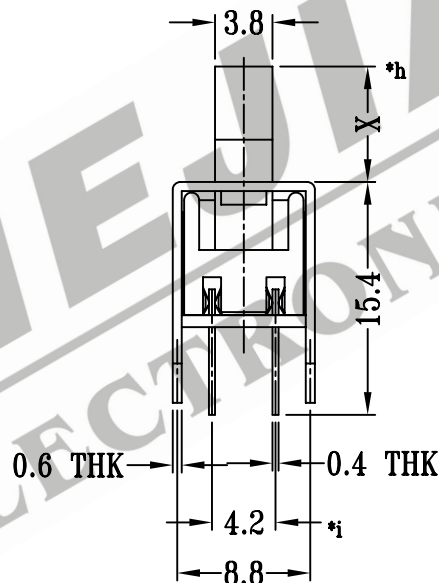
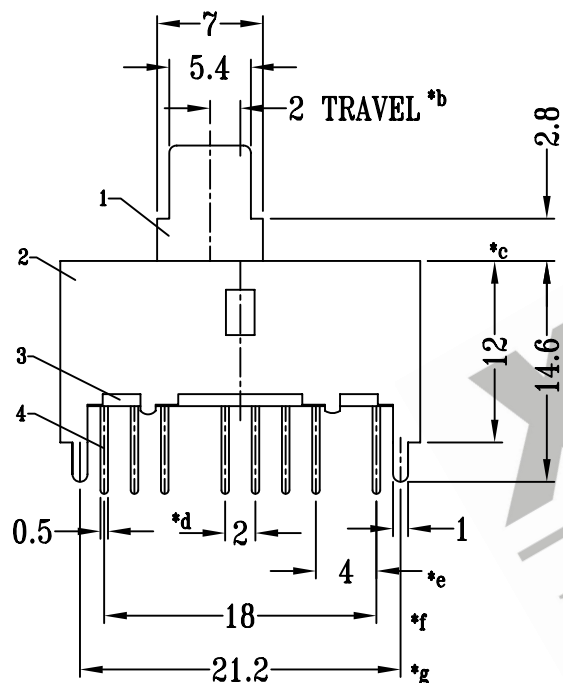

P.C.B LAYOUT

注:带"*"表示关键尺寸(9个)

NO.	PARTS	MATERIALS	Q'TY	FINISH	TOLERANCE UNLESS SPECIFIED	SHENZHEN XIEJIA ELECTRONICS CO.,LTD.				
8						TITLE : VERTICAL SLIDE SWITCH MODEL: SS-43D31				
7	STEEL BALL	STEEL	2	NATURAL						UNIT : mm
6	SPRING	STEEL WIRE	1	TEMPER	WITHIN : 1.5±0.1mm OVER : 1.5±0.2mm	SCALE: 2:1		DWN.	ZHOUYU	2005-12-24
5	CONTACT CLIP	PBS STRIP	4	Ag PLATED		ISSUE	DATE	DESCRIPTIONS OF REVISION		APPD.
4	TERMINAL	BRASS STRIP	16	Ag PLATED OVER Ni PLATED				CHK'D	FANGYING	2005-12-24
3	BASE	PHENOLIC RESIN	1	NATURAL				APPD.	KANGXINAN	2005-12-24
2	FRAME	STEEL STRIP	1	Ni PLATED						
1	KNOB	POM	1	BLACK						
ALL MATERIALS MUST BE COMPLIANT TO ROHS										